

# Application Note – AN218

## Vehicle Detection Using AMR Sensors

### ABSTRACT

The ever increasing need for automated vehicle sensing has brought about interest in Honeywell's Anisotropic Magneto-Resistive (AMR) sensors as an upgrade from older and simpler vehicle detection systems. With the small size and simplicity of these wheatstone bridge based sensors, many applications are now able to deploy many of these sensors cost-effectively, and gain more information on nearby vehicles. This application note shall describe the various applications of vehicle detection, the various hardware and software techniques of vehicle detection, and a couple example designs describing AMR sensor integration and operation for potential designers.

### VEHICLE DETECTION APPLICATIONS

Vehicle detection technology has evolved quite a bit in the last couple decades. From air hoses to inductive loops embedded in roadways, most legacy detection methods were concentrated on getting vehicle presence information to a decision making set of control systems. Today we want so much more information; and information such as speed and direction of traffic, the quantity of vehicles per time on a stretch of pavement, or just very reliable presence or absence of a class of vehicles.

Appealing to the fact that almost all road vehicles have significant amounts of ferrous metals in their chassis (iron, steel, nickel, cobalt, etc.), magnetic sensors are a good candidate for detecting vehicles. Today, most magnetic sensor technologies are fairly miniature in size, and thanks to solid state technology, both the size and the electrical interfacing have improved to make integration easier.

But not all vehicles emit magnetic fields that magnetic sensors could use in detection. This fact eliminates most "high field" magnetic field sensing devices like Hall Effect sensors. But mother-nature provides us with earth's magnetic field that permeates everything between the south and north magnetic poles. The earth's magnetic field is around a half-gauss in magnetic flux density; so "low field" magnetic sensors are used to pickup this field, and also the field disturbances that nearby vehicles will create. Figure 1 shows a good graphical example of the lines of flux from the earth between the magnetic poles, and the bending they receive as they penetrate a typical vehicle with ferrous metals.

As the lines of magnetic flux group together (concentrate) or spread out (deconcentrate), a magnetic

sensor placed nearby will be under the same magnetic influence the vehicle creates to the earth's field. However because the sensor is not intimate to the surface or interior of the vehicle, it does not get the same fidelity of concentration or deconcentration. And with increasing standoff distance from the vehicle, the amount of flux density change with vehicle presence drops of at an exponential rate. This is good and bad, depending on your design concerns. If detection distance is highest priority, a high drop-off in flux density is bad. However, if not false detecting an adjacent lane or vehicle in the adjacent parking spot, a high drop-off in flux density change is very good news.

Typical vehicle detection applications using magnetic sensors and earth's field are:

- Railroad Crossing Control (for trains)
- Drive Through Retail (Banking, Fast-Food, etc.)
- Automatic Door/Gate Opening
- Traffic Monitoring (Speed, Direction)
- Parking Lot Space Detection
- Parking Meters

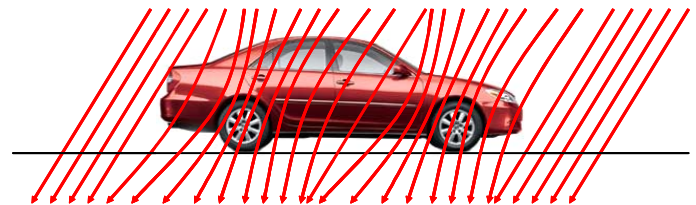

Figure 1 - Earth's Magnetic Field Through Vehicle

### MAGNETIC SENSOR HARDWARE

Low field magnetic sensors come in two categories, magnetoresistive bridges, and coils. While coils can create magneto-inductive and flux-gate magnetic sensors, in general they tend to be larger in size, and required active oscillator circuits to determine the amount of magnetic flux influencing the coil(s). With magnetoresistive sensors, two types are available, called AMR and GMR. AMR or Anisotropic Magneto-Resistive sensors are directional sensors and provide only an amplitude response to magnetic fields in their sensitive axis. By combining AMR sensors into two or three axis configurations, a two or three dimensional measurement of the magnetic fields passing through the sensors is possible with excellent linearity.

GMR or Giant Magneto-Resistive sensors can also be used for low magnetic field sensing, but have a broad sensitivity to amplitudes with little directionality. For

vehicle detection, GMR sensors must have a nearby magnetic bias field, from either a permanent magnet or DC driven solenoid to gain improved linearity. In the following discussions, we will confine discussion to AMR sensors for vehicle detection applications.

For AMR sensors, the sensor resistive elements are oriented as a resistive “wheatstone bridge” that varies resistance slightly as the magnetic field changes upon each element. The resistive elements are made of permalloy thin films and have around 1000 ohms of resistance, but each element is precision matched to within an ohm of each other when no magnetic fields are present. Figure 2 shows a typical AMR sensor wheatstone bridge electrical diagram.

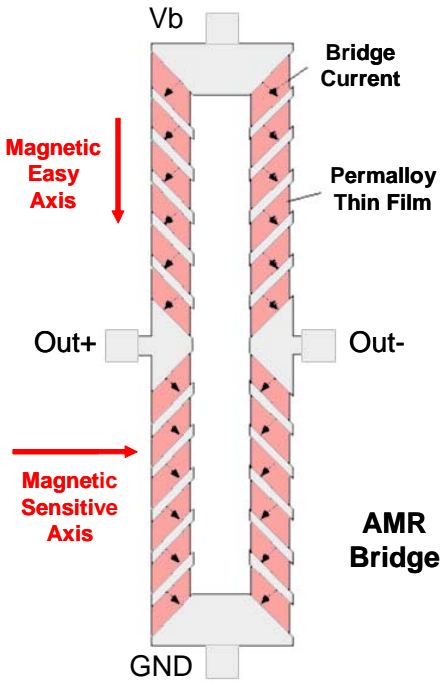

Figure 2 - AMR Sensor Bridge

Each bridge has four resistive elements with opposite elements being identical. For example, if the bridge receives a positive magnetic field or lines of magnetic flux in the sensitive axis, the Vb to Out+ and Out- to GND elements will slightly decrease in resistance while the other two elements will increase in resistance. The result will be that the voltage at Out+ increases above Vb/2 and the voltage at Out- decreases from Vb/2. If the bridge voltage, or Vb, equals 5 volts and the applied magnetic flux is 0.5 gauss, the nominal voltage at Out+ is 2.5012 volts and the nominal voltage at Out- is 2.4988 volts.

The amount output voltage from the AMR sensor is measured from Out+ to Out- and is a function of the sensor sensitivity equation, or:

$$\text{Out+} - \text{Out-} = S * Vb * Bs \quad \text{with,}$$

S = Sensitivity (nominally 1mV/V/gauss)  
 Vb = Bridge Supply Voltage in volts  
 Bs = Bridge Applied Magnetic Flux in gauss

In the above example, a 5 volt supplied bridge with a 0.5 gauss magnetic flux in the sensitive axis, creates 2.5 milli-volts of bridge output voltage.

By combining two AMR sensors together, the part becomes a 2-axis sensor and when mounted horizontally, is able to break any horizontal magnetic fields into X and Y vector components. Figure 3 shows this sensor combination in the Honeywell HMC1022 sensor product.

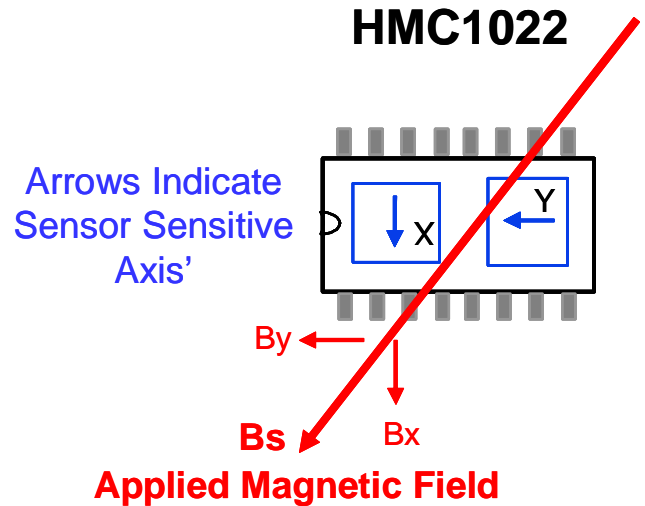

Figure 3 - 2-Axis Magnetic Field Sensing

If magnetic field, Bs, is the earth’s magnetic field in the horizontal direction, the sensors in the HMC1022 integrated circuit package break the field down into Bx and By vector components. This way Bx and By represent both the direction and amplitude of Bs. For vehicle detection, the direction and amplitude of Bs could change as the vehicle approaches the sensors in the HMC1022 package. While a single AMR sensor (like the HMC1021) could note a shift of a single axis, having 2-axis sensors could more reliably detect vehicles at the edge of the detection range and provide an “all orientation” assurance in detection.

As you will see in succeeding sections, the choice of one, two, or three-axis magnetic field sensing is a trade off in performance versus cost. The single axis system will require only one sensor, one set of sensor interface electronics, and one input to digitize and place into a threshold detection algorithm. Using parts like the HMC1022, or the HMC1052 and HMC1053 multi-axis sensors provides extra axis for mounting flexibility.

### MAGNETIC SENSOR INTERFACE CIRCUITS

Because the AMR sensor outputs are in small millivolt levels given earth’s magnetic field strengths, these wheatstone bridge sensors require follow-on amplification to make vehicle induced field changes easier to detect. With the differential output of the sensors, each sensor requires a differential or

instrumentation amplifier stage compatible with the sensor output voltages and the sensor bridge supply voltage. Typically, these amplifier stages will operate from either 4.8 to 5.2, or 2.7 to 3.3 volt power supply rails to conserve energy in battery applications, or higher voltages if supplied from non-portable sources. As you can see from the sensitivity equation, bridge supply voltages help amplify the signal. But running the sensors beyond 5 volts also puts more milliwatts of heat onto the bridge elements making thermal drift effects more noticeable. Figure 4 shows a typical sensor interface circuit schematic.

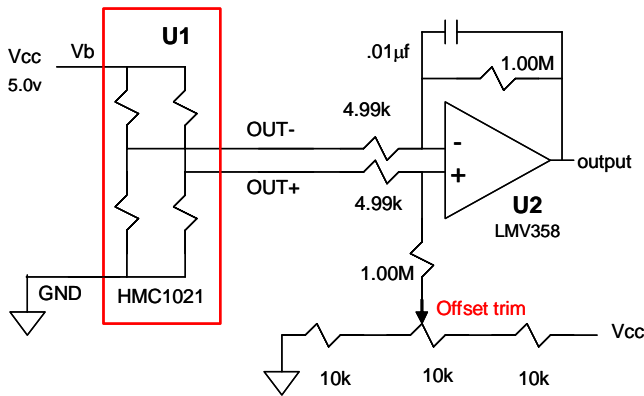

Figure 4 - AMR Sensor Amplification

As shown, a common low voltage operational amplifier (LMV358 op-amp) is depicted with four 1% tolerance metal film resistors to create a 200V/V gain difference amplifier. A dedicated instrumentation amplifier can replace the op-amp and resistors for simpler control over gain and offset voltage at the expense of a bit more cost for the amplifier. This circuit takes the difference in voltage of the sensor OUT+ and OUT- nodes, and then amplifies the result as a bias voltage value from the offset voltage reference. The offset voltage reference will be node voltage on the wiper of the offset trim potentiometer.

As an example, let the sensitive axis field of the sensor in Figure 4 be 0.5 gauss with a bridge and amplifier power supply rail (Vcc) be 3.0 volts. Because of the 1.0mV/V/gauss sensitivity of the HMC1021, the differential output voltage of the sensor will be +1.5 millivolts. As applied to the amplifier with a gain of 200, the amplifier output will be 300 millivolts positive from the offset reference voltage. Given an offset voltage of half supply (1.5 volts), the measured output voltage at the amplifier would be about 1.80 volts.

Because the AMR sensors are not perfectly matched at the resistive elements, a bridge offset voltage results; and is different for each sensor manufactured. However the good news is that this offset is fixed for the part's life with the remaining drift due to temperature changing the resistance of the bridge elements. This bridge offset voltage is dependant on the bridge supply voltage and is scaled on a millivolts per bridge voltage (mV/V). For the

HMC102X family of sensors, the specified range of bridge offset is about 2mV/V with normal distribution of under the  $\pm 0.5\text{mV/V}$  range. Using the Figure 4 circuit example previously, a -0.5mV/V bridge offset on a 3 volt power supply provides a -1.5 millivolt output offset, or a -300 millivolt offset at the amplifier. To null this offset, one method is move the offset reference voltage from 1.5 volts to 1.8 volts to counter the bridge offset. For further offset reduction methods, see application note AN212 on the [magneticsensors.com](http://magneticsensors.com) website.

Honeywell AMR sensors also have patented coils interleaved with the bridge elements for many purposes. These coils are intended for creating a "magnetic offset" field, or to re-align the magnetic domains of the permalloy thin film with the easy axis after excessive magnetic fields upset the sensor magnetic domain direction. These coils are called the "offset strap" and the "set/reset strap" as they have minimal inductance and electrically thought of as resistive elements with the amp-turns aspect of the coils applying localized fields on the sensors. Figure 5 shows the schematic representation of the HMC1022 sensor with its straps.

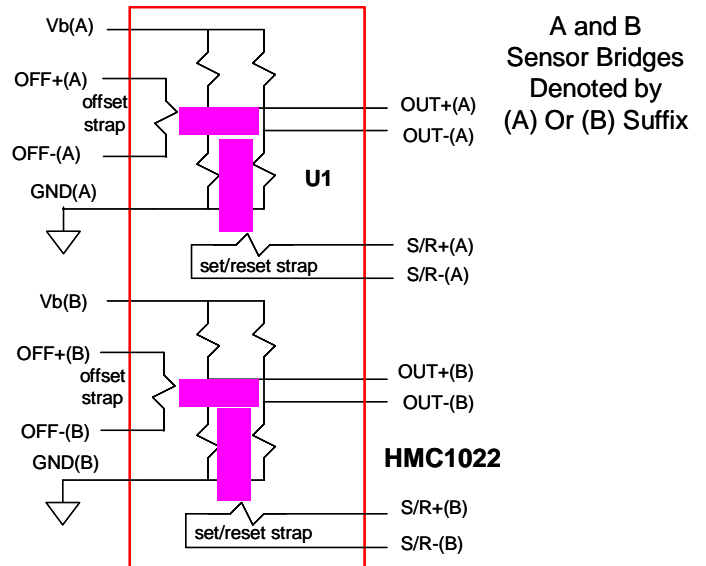

Figure 5 - HMR1022 With Straps Shown

The offset straps convert currents through the strap resistance into a local magnetic field upon the bridge elements in the sensitive axis direction. By creating magnetic offset fields, the sensor bridges will sum both the desired magnetic far field and the offset strap produced field to buck, boost, or just center up the summed fields for best amplification and signal processing. A majority of vehicle detection applications do not use the offset straps, and may be left open circuited if not used.

The set/reset straps are intended for pulsed currents to "degauss" or "de-perm" the sensor bridges as required to avoid sensor performance degradation after exposure to accidental high magnetic fields. These high fields are

generally in excess of ±10 gauss at the bridges, and typically caused by magnetized hand tools, permanent magnets, portable electric motors, and high current wires such as welding cables. By periodically sending moderate current pulses at convenient intervals, the permalloy thin film magnetic domains get re-aligned in the easy axis directions and the memory of the upset field direction is erased. This process is much like erasing audio recording tape since they both employ permalloy films.

Application note AN213 describes the set/reset strap feature in detail with typical pulse drive circuits. For vehicle detection applications, a periodic repetition of reset followed by set pulses is recommended at one second to minute intervals. Should the sensors be magnetically upset via high field exposure, the exposure could result in reduced sensitivity, or no change in sensor voltages (stuck sensors), until the set/reset straps are pulsed. Figure 6 shows a typical single set/reset strap drive circuit optimized for 5 volt supplies and a HMC1021 set/reset strap.

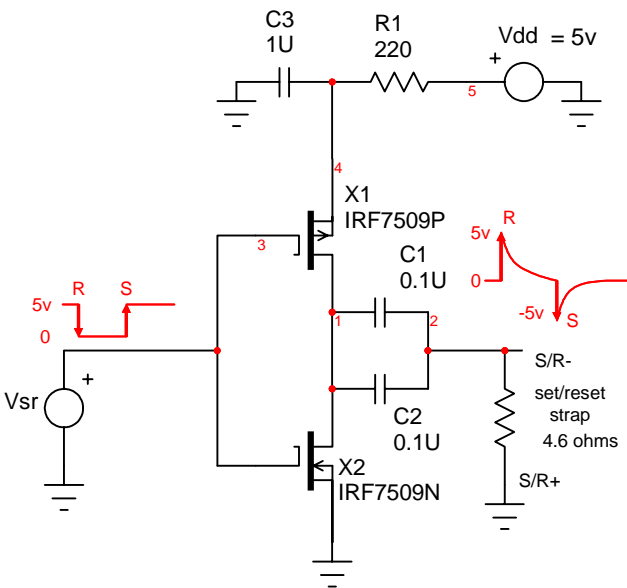

Figure 6 - Set/Reset Strap Driver Circuit

**VEHICLE DETECTION SIGNATURES**

Using the earth’s magnetic field provides a magnetic background or “bias” point that stays substantially constant with a fixed sensor installation. With the earth’s magnetic field strength at about 0.5 gauss and further reduced to just a single axis amount from a possible three-axis orientation, each sensor may have signal ranging from near zero gauss to ±0.7 gauss in natural earth signal dynamic range. As vehicles come into proximity to the sensor, the shift from the earth’s field levels comes from both soft and hard-iron sources from the vehicle. Soft-iron is ferrous materials that concentrate magnetic flux into the material and do not have any remnant flux generated within the material. Hard-iron sources are materials that have flux

concentration abilities and can have remnant flux generation abilities. While the flux density could be in the hundreds of gauss, most vehicles with hard-iron carry much less than ±2 gauss of remnant flux due to stamping of the chassis metals.

Soft-irons will concentrate the earth’s magnetic flux, but typically will only increase the flux amplitude less than half the residual bias value at the sensor location. And if the fields are concentrated in the soft-iron, then they tend to de-concentrate the flux perpendicular to the field direction as shown in Figure 1. So the magnetic sensors will likely see a few tens to hundreds of milligauss of earth’s field bias with up to ± 3 gauss of spikes as statistically typical vehicles come into proximity with the sensors. Vehicle detection product designers are not likely to care about the dynamic peaks of the vehicle induced magnetic signatures, but are likely to design in a ±1 gauss dynamic range and use sudden shifts from the bias values as vehicle detection criteria.

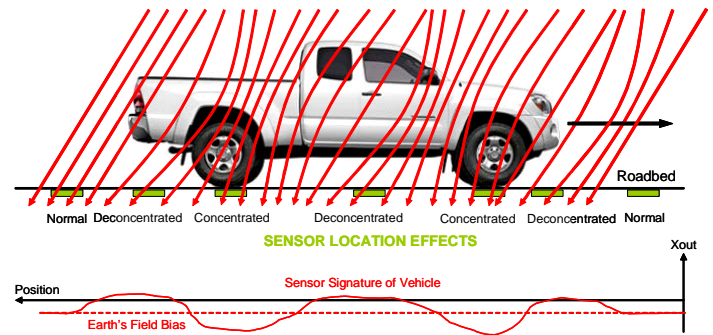

Figure 7 - Vehicle Signature

The above figure shows a typical North American magnetic field direction with the truck moving southbound. The green boxes represent possible sensor locations near the roadbed and the relative amounts of flux concentration they could sense. The adjoining graph shows what a signal axis sensor bridge might see when it has the sensitive axis also pointing southbound and as the truck drives past the sensor. Since the natural earth’s magnetic field would bias the sensors with a slight negative voltage output, increasing flux concentration would further lower the voltage, and decreasing concentration would raise the voltage.

Sensors oriented sideways (horizontal, across the roadbed) and vertical would likely also shift during the vehicle passage, but the bias values and signature shifts would be different. For most applications, the amplitude and direction of voltage shift is not important, but the detection of a significant shift in output voltage is what would matter most. For vehicle presence applications, the vector magnitude shift from the earth’s magnetic field would be the most reliable method. Using digitized measurements of three-axis sensor outputs after amplification, the vector magnitude would be:

$$A = \text{SQRT} ( X^2 + Y^2 + Z^2 )$$

As a vehicle parks alongside or overtop the magnetic sensor location, the magnitude would shift suddenly from the earth's bias (no-vehicle) magnitude. This would be most applicable for parking meters, parking space occupancy, door openers, and drive through service prompting.

Note that the amount of sensor output shift has a large dependence on proximity of the sensors to the vehicle. As the vehicle is within inches of the sensor, such as on the middle of the roadbed lane at the surface; the signature will have quite a bit detail and will pickup the intricacies of the ferrous construction of the vehicle chassis. Further away, such as one meter, the vehicle signature may be a tenth in magnitude depending on the vehicle size and the signature bandwidth looks more as a flux contraction hump than a squiggle. As the distance increases the signature changes from flux concentration to deconcentration to returning to the baseline. Table 1 shows a typical automotive magnitude (flux density) versus sensor standoff distance.

Standoff Distance	Flux Density Shift
1 foot	270 milligauss
3 foot	75 milligauss
5 foot	10 milligauss
10 foot	2 milligauss
12 foot	<1 milligauss

Table 1

### VEHICLE DIRECTION SENSING

In the previous truck vehicle signature example, a single sensor was shown as the vehicle overpasses it on the roadbed. This traditionally is known as a X-axis system since it uses the sensitive axis in the expected vehicle direction. By employing a sensor off the side of the vehicle path, basic vehicle direction can be detected. See Figure 8 for a typical sensor placement for vehicle direction detection.

In the figure, as the vehicle approaches the sensor, lines of magnetic flux begin to bend at the sensor toward the vehicle. Thus the flux density decreases and the signature voltage from the sensor goes negative from its bias value. As the vehicle leaves the sensor, the flux density chases the vehicle and a positive signature voltage results. If the vehicle backs up or returns in the opposite direction, the signature plot looks like a mirror image.

A second and more reliable method involves two sensors displaced by a small distance apart, but with their sensitive axis' in the same direction. The intent is that a vehicle in motion will create the same signature, but displaced in time.

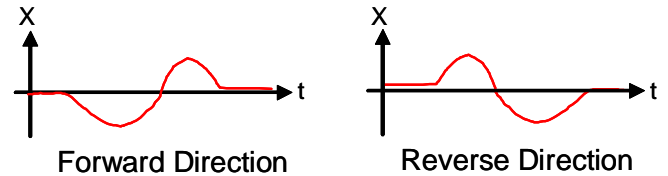
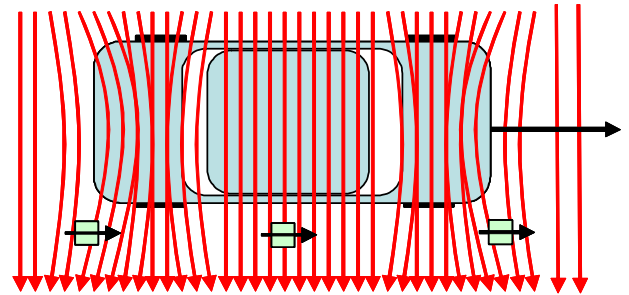

Figure 8 - X-Axis Direction Sensing

With the dual displaced sensors, the rear sensor will hit the detection threshold a fraction of a second before the front sensor in forward traffic. And the opposite occurs in reverse direction traffic. With a known displacement distance and a reasonably precise time measurement between threshold detections, a speed computation can be made as well. Figure 9 depicts this typical mounting.

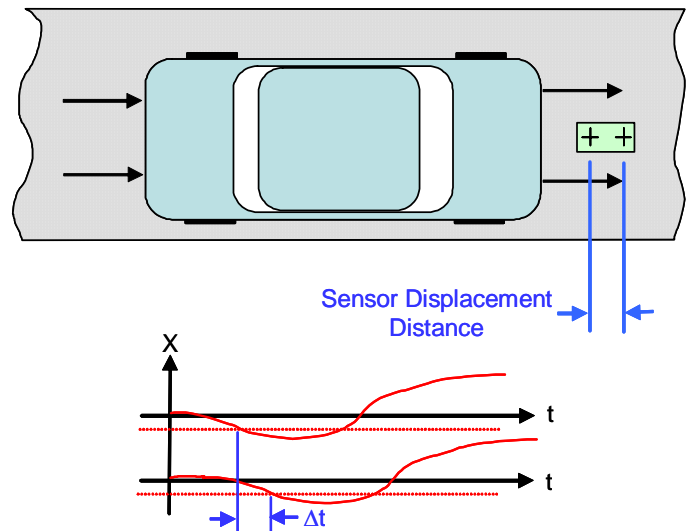

Figure 9 - Dual Displaced Sensors

The displacement distance of the sensors does not have to be a very large value. With today's high speed microcontroller's and precision analog circuitry, speed measurement accuracy and resolution can be within single mile per hour gradations.

### VEHICLE DETECTION FALSING

The biggest concern of vehicle detection system designer is receiving false presence of vehicles, or "falsing". While vandals may toss magnets onto your

sensor areas, most falsing concerns come from nature-made stimuli or adjacent lane vehicles

From Table 1 earlier in this document, adjacent lane falsing may be a matter of just setting magnetic shift threshold to the optimum amount of milligauss, and choosing a middle of lane location. One of worst-case traffic detection problems is a large truck in an adjacent lane creating enough flux bending in an empty lane sensor to cause falsing. Figure 10 depicts this scenario.

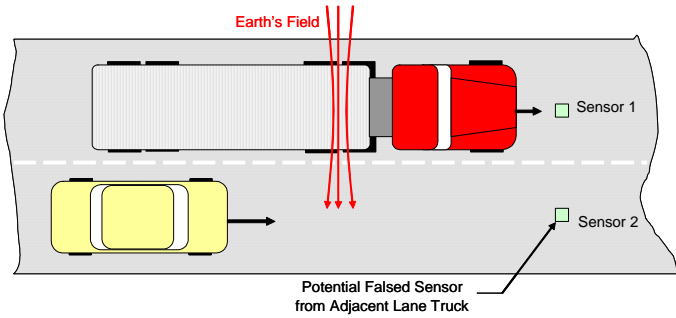

Figure 10 - Adjacent Lane Falsing

If the road is only two lanes wide, you may be able to slightly locate the sensor assemblies toward the outer lane edges to gain a bit of falsing rejection. The other challenge in setting the flux shift threshold is that too large of a threshold may prevent desired vehicles, such as motorcycles and a small autos with a lot of composite chassis from being detected.

Another falsing scenario comes from the fact that mother nature will vary the earth's field amplitude by small amounts day-to-day and minute-to-minute. While a couple of milligauss shift is fine with magnetic sensors used as a compass, vehicle detection systems may trigger falsely if they can not discriminate for natural drifts. Either via analog signal processing, or detection algorithm software; small, slow changes in earth's magnetic field values should be rejected. Software algorithm's should be able to continuously update the "bias" values to ensure the threshold stays the correct amount apart from the bias values for each axis. Analog circuits can implement slow time-constant threshold voltages in the vehicle detect comparator signal processing to reject slow signature shifts and trigger only on fast rising voltages.

A third falsing scenario occurs when temperature on the AMR sensor changes rapidly. The worst-case scenario is on summer partly cloudy days when the sun comes out of the clouds and suddenly begins baking the housing containing the sensors. While reasonable thermal design of enclosures will help, other electrical techniques will additionally help prevent falsing.

The temperature falsing occurs when the AMR sensor bridge offsets change as the sensor permalloy thin films change temperature. This tempco is nominally -3100 parts per million per degree celsius (-3100ppm/°C). So a 1.5 millivolt bridge offset at 25°C, becomes 1.48 millivolts bridge offset at 30°C. The 20 microvolt shift with 5°C change in temperature may not seem a problem, but it could result in a 20 milligauss equivalent shift with a 3 volt bridge supply voltage. And with an amplifier section gain of 200, that temperature change could be a 4 millivolt change in analog output voltage.

As mentioned earlier in this application note, you can use the set/reset function for many uses. By taking magnetic field measurements after the reset pulse (reverse polarity), and the set pulse (normal polarity); the sum of the measurements subtracts off the external magnetic field influences, leaving twice the bridge offset voltage. Then dividing by two retrieves the most recent bridge offset at the current temperature. By doing the set/reset pulses at every few second intervals, sudden heating or cooling effects on sensor bridge offset are detected and corrected. Figure 11 shows the typical scenario.

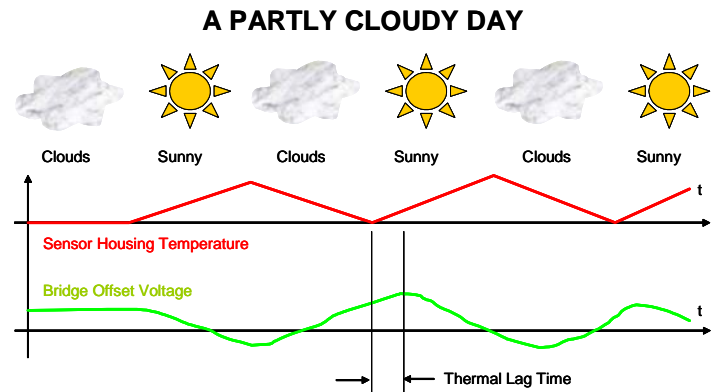

Figure 11 - Thermal Falsing Effects

### SIMPLE VEHICLE DETECTION CIRCUIT

As a way to ease into vehicle detection circuit design, a simple one-axis, all analog circuitry example will be described below. Choosing a HMC1021S for simplest prototyping, Figure 12 shows the typical schematic diagram for this circuit.

Taking recommendation from earlier in this application note, a ±1 gauss dynamic range is recommended, and with a 5 volt bridge supply on the HMC1021S, a ±5mV output would result. To span a 5 volt supply, a gain of 500 would permit ±2.5 volts outputs centered at 2.5 volts (zero gauss point). The HMC1021S can be substituted with any of the HMC102X, HMC104X, and HMC105X families of magnetic sensor components; as all have the 1mV/V/gauss sensitivity specification.

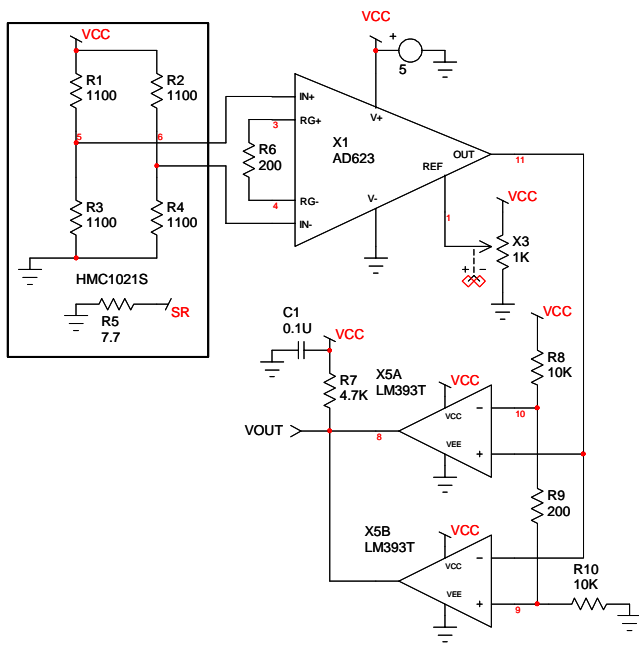

Figure 12 - Simple Vehicle Detection Circuit

In the figure, the low cost instrumentation amplifier (AD623) is gained for 500V/V, and the 1k-ohm potentiometer on the amplifier's reference pin permits nulling of both bridge offset and the earth's magnetic field bias value. The two LM393 comparators form a window comparator circuit, in which the instrumentation amplifier will be trimmed by the 1k-ohm potentiometer to be centered in the 0 to 5 volt power supply system.

Resistors R8, R9, and R10 are chosen so that if the amplifier output strays significantly from the 2.5 volt trim value, one of the comparators will pull the output (VOUT) to a logic low state. By choosing the value of R9 correctly, or by substituting a 500-ohm potentiometer in a rheostat configuration, you can adjust the vehicle detection distance.

By choosing a 200-ohm resistor value, the window comparators have about a  $\pm 25$  milli-volt window around 2.5 volts to trigger from. With everything trimmed properly, the  $\pm 25$ mV divided by the instrumentation amplifier gain equates to about  $\pm 50$  micro-volt magnetic sensor stimulus window or a  $\pm 10$  milli-gauss detection shift range from the 1mV/V/gauss sensitivity.

This circuit will certainly be susceptible to falsing by earth's field drifts and temperature drifts, but users can retrim the 1k-ohm potentiometer periodically to re-center the no vehicle present bias back to 2.5 volts. Obviously this simple circuit would not be acceptable for install and forget applications. However, many designers will implement a microprocessor-based system that would implement continuous gain and offset controls to keep the system centered to prevent slow-drift falsing. As designed, the simple vehicle detection circuit shown has

the  $\pm 25$ mV shift sensitivity, which approximately equates to a 4 foot automotive detection distance based on nominal signature data in Table 1.

## VEHICLE DETECTION USING DIGITAL MICROCONTROLLERS

Both the analog amplifier circuits from Figures 4 and 12 are good enough for most vehicle detection applications, but better detection schemes can be implemented when the mathematical power of digital microcontrollers are used. Figure 13 is a typical schematic of digital vehicle detection system using a HMC1052L and PIC16 micro controller.

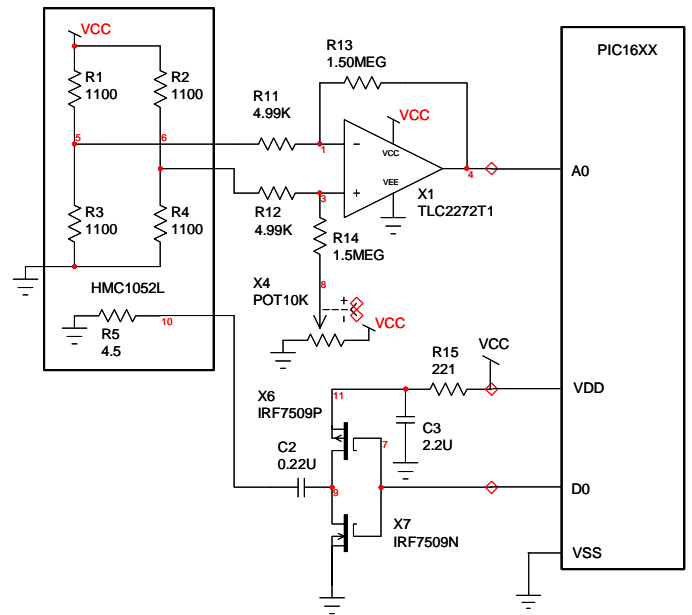

Figure 13 - Microcontroller-Based Vehicle Detection Circuit

This circuit has several noticeable changes from the Figure 12 circuit in that the instrumentation amplifier is now replaced by an op-amp configured as a difference amplifier and the HMC1021S is replaced by a HMC1052L. Not shown is the second HMC1052 bridge circuit, but a second duplicate circuit can be laid out and take another multiplexed 10-bit ADC input (D1) from the PIC16XX microcontroller. The second bridge is the orthogonal axis (Y-axis) sensor, and can be used to give an all horizontal orientation vehicle detection system. Also shown is the automatic set/reset strap driver circuit for periodically refreshing the sensors. Since the HMC1052L uses one common set/reset strap for both bridges, the dual MOSFET driver design can be used with 5 volt logic compatible gate thresholds.

The difference amplifier in Figure 13 is set for a 300V/V gain for a couple reasons. The first is the desire for the  $\pm 1$  gauss magnetic flux dynamic range, and the other is the fact that some headroom will need to be given for the HMC1052L bridge offsets, as the 10k potentiometer will

be factory adjusted once for bridge offset. Once set, all drifts for thermal and earth's magnetic field bias will be handled by the PIC16XX microcontroller and its multiplexed 10-bit ADC.

This circuit is assumed to be operating at 5 volts, so the  $\pm 1$  gauss input range equates to  $\pm 5$ mV at the sensors, and  $\pm 1.5$  volts at the PIC16XX ADC inputs. The 10k pot will then be set for 2.5 volts, given a zero field on the sensor bridges. Then the remaining volt to the supply rails is for thermal drift, amplifier rail backoffs, and magnetic signature peaks. The reference of PIC16XX is shown generically since the designer could use any variant of the PIC 16 series family, or any other equivalent brand or series microcontroller.

With a microcontroller, vehicle detection now becomes discontinuous, or sampled for a signal beyond the upper and lower thresholds. So the sampling interval must be fast enough to catch the fastest expected vehicle speed past the sensors. And this can become interesting for traffic and drive-up service applications as multiple sensors are likely to be used with each fed into a multiplexed input of a microcontroller's internal ADC.

Writing firmware for the vehicle detection algorithms becomes an application specific and usually a proprietary piece of code that may be patent protected. However, most designs will have the common issue of digitizing the sensor input voltages from the amplifiers, and comparing the latest data point with the threshold numbers. As a classic example, Figure 14 shows a detection algorithm plot with drift compensation.

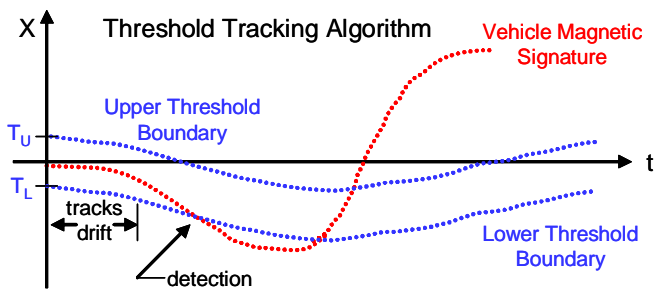

Figure 14 - Detection Algorithm

A simple detection algorithm could just measure the earth's field bias value and set upper and lower thresholds based on a fixed amount for a desired detection range on a reference vehicle. But thermal drifts and magnetic field drifts could trigger a false detection, unless the thresholds are allowed to drift by an ADC count or two with each sensor measurement. As a vehicle approaches the sensor, the amount of ADC change in "counts" will change faster than the drift compensation algorithm can be allowed to shift, thus resulting in a valid vehicle detection.

To better show how this works, a 10-bit ADC has 1024 ADC "counts", and typically count 512 is the nominal

zero gauss trim value. Thus counts below 512 are negative numbers and are likely represented by two's complemented digital values. So a typical firmware routine will make the sensor data acquisitions, subtract 512 counts to zero the latest data, and compare against the threshold values for a vehicle detection decision (yes/no). After the decision, new thresholds are computed based on new to previous sensor sampled counts.

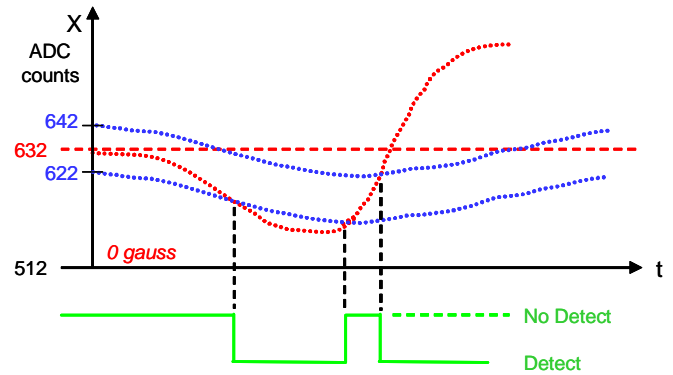

Figure 15 - Digital Detection

Using Figure 15 above, if the earth's magnetic field bias is at 632 counts, or 120 counts above zero gauss; then threshold limits of  $\pm 10$  counts could be a reasonable given about 5mV per count, 300 counts per gauss, for a  $\pm 33$  milli-gauss band of thresholds shown in the blue dots. Depending on the system noise, the threshold bands are bandwidth limited by preventing no more than a certain amount of counts shift per number of samples. This permits real vehicle magnetic signatures to out-race the change in thresholds to discriminate between drifts and vehicles. The green logic output trace shows the logical result when using adaptive or drift compensating threshold detection.

## MIXED-SIGNAL VEHICLE DETECTION

In the previous example circuit, the downside of using digital logic detection algorithms is that the continuous sensor output is broken into samples and applied to a firmware detection algorithm. But if your vehicles are moving at high speeds, the detection is as only as good as the slowest process, and that maybe too slow for the reaction time needed.

To keep the detection continuous, an analog system can be designed much like the simple detection circuit, but with analog drift compensation for falsing rejection. Figure 16 shows a typical design example using an instrumentation amplifier, op-amps, and comparators to continuously monitor the magnetic signal. Also a microcontroller can be used to handle maintenance functions like periodic set/reset function, offset bias and gain adjustments, and detection distance adjustment.

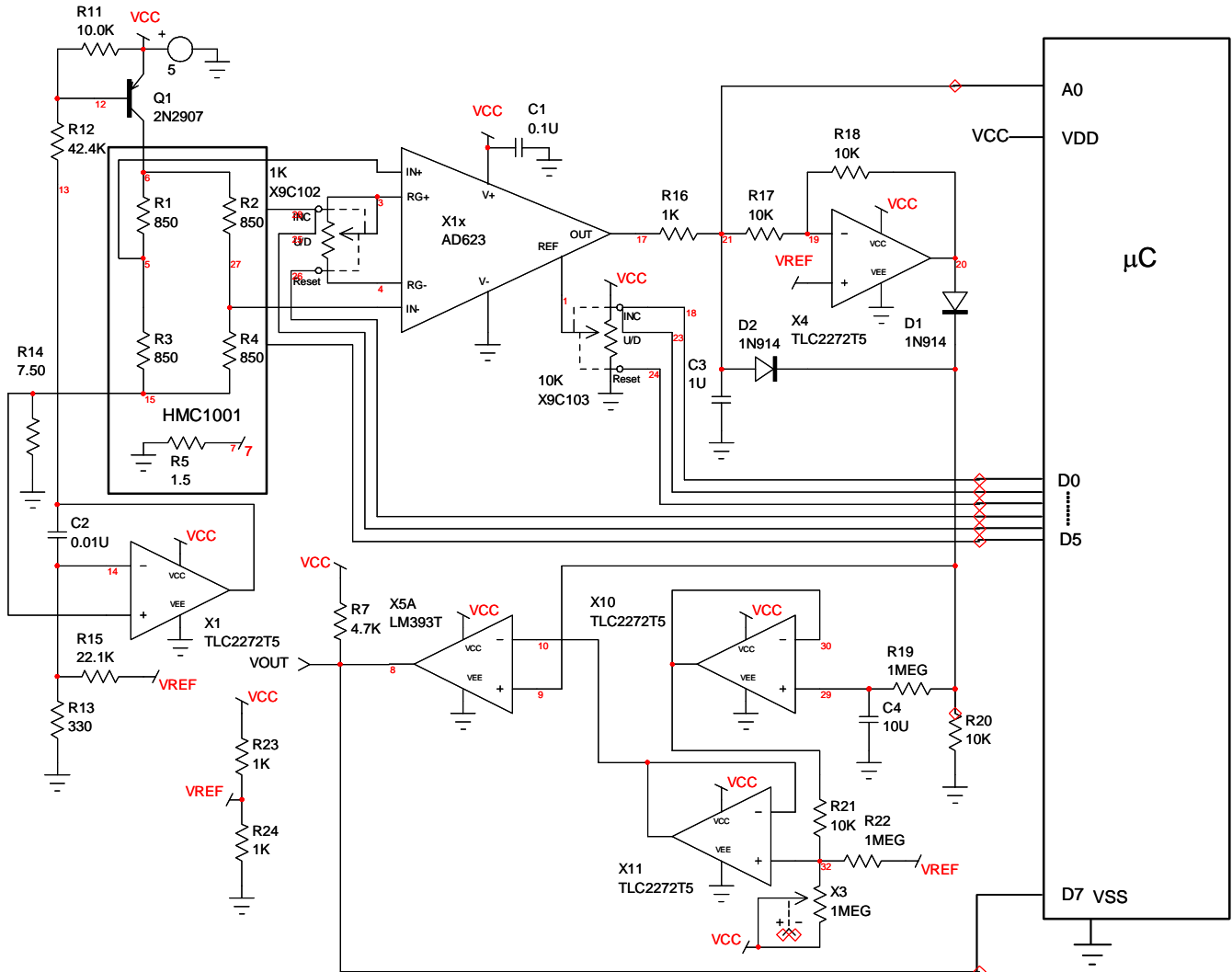

Figure 16 - Mixed Signal Vehicle Detection Circuit

From the figure, several new features are introduced. The first is the constant current source drive of the HMC1001 sensor bridge. The HMC1001 is Honeywell's most sensitive AMR sensor, but has a slightly lower bridge resistance (850 ohms) and has larger permalloy elements to provide a nominal 3.2mV/V/gauss sensitivity. By feeding the HMC1001 with about 4.7mA, room temperature voltage across the bridge is about 4 volts from the total 5 volt supply range. The intent of the constant current source is to further stabilize the bridge offset drift specification from about 3000ppm/°C to 600ppm/°C. This reduction in thermal drift allows for less total drift and more drift compensation focus on the earth's bias field drift.

Another new feature is the implementation of two digitally controlled potentiometers around the instrumentation amplifier. This allows the microcontroller to sample the post-amplifier output and make gain and offset voltage adjustments for optimum performance. Part of the amplifier circuit is the output low-pass filter

implemented by the R16/C3 network to limit bandwidth to low audio frequency signals that would likely be the fastest vehicle signature movement in the sensor.

The next new feature is the full wave rectifier circuit after the amplifier stage to fold back any negative shifted signal with vehicle approach. This allows for a single threshold detection scheme instead creating a window detector presented in Figure 12.

Following the rectifier, the filtered and rectified vehicle signature signal is directly placed to the comparator for threshold detection. The other comparator input comes from two op-amp stages that form an analog adaptive threshold circuit. The vehicle signature signal is drastically filtered by R-C network R19/C4 to create the slow drifting baseline bias that will track slow bridge offset voltage and earth's magnetic field drifts with a several second time constant. This voltage is then buffered and then sent to a summing amplifier stage that sums the voltage from the slow drift signal plus a DC voltage that becomes the milli-volt threshold for vehicle detection. The one mega-ohm potentiometer is adjusted for best vehicle detection distance and falsing rejection.

The output of the comparator is the normally high logic vehicle detect signal can be used to trigger further control system inputs for the chosen application. Note that the microcontroller only is used to handle maintenance functions, and does not have a lag time other than the filters chosen in the circuits. While complex in implementation, the Figure 16 circuit is in fairly common usage for traffic detection and railroad crossing type applications.

**LOW POWER VEHICLE DETECTION**

While the bridge element resistance in the sensors is moderately low impedance and difficult to constrain power consumption, some tactics are available to keep power or energy consumption low for battery operated designs. The tactic is to lower power supply voltage to the 2.7 to 3.3 volt battery supply range. This can be accomplished by careful selection of amplifiers, ADCs, and microcontrollers optimized for low current draw as well as low voltage operation.

Another tactic is to determine a sampling method for vehicle detection by using the microcontroller example circuit and by choosing the minimum amount of samples per second. Since the AMR sensors have a 5MHz bandwidth and are almost completely resistive, the settling time for snapshot measurements are in the nanoseconds. By powering-on the vehicle detection amplifiers and sensors, and letting them settle for a millisecond or less, you can “duty cycle” down the total energy expended and still have quality magnetic signature measurements without expending much battery capacity.

**SUMMARY**

The need for smart sensors in Intelligent Traffic Systems (ITS) and related applications makes these AMR sensors very good candidates for vehicle presence, speed, and direction data gathering. Compared to optical, ultrasonic, and inductive loop solutions, the sensors offer the possibility of very small size installations into and onto roadway structures for reliable function.

In the railroad crossing application, AMR sensors can easily detect locomotives from 20 meters away. This means very reliable detection from track roadbed positions.

The drive-through retail application for vehicle detection and tracking has been exploding in recent years, and the amount of data precision is forcing better technology

usage. Figure 17 shows a typical depiction of in-roadbed sensor locations to track customer vehicles from order-taking, to payment, to service delivery positions.

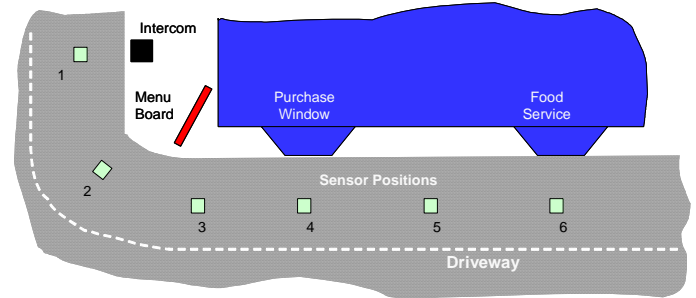

Figure 17 - Fast Food Vehicle Detection Example

Automatic door and gatekeeping can be made simple and low cost using AMR sensors by recording background field levels and controlling for vehicle-waiting and vehicle parked logical decisions. A classic example is overhead door lifting for factory forklift transit through door thresholds.

With Traffic Monitoring, vehicle detection ranges from simple inductive loop replacement to multi-lane speed and direction sensing for ITS networks. Both wired and wireless sensor mounts would apply in this application.

Parking space and parking meter applications have similar constraints for low-cost and reliable presence/absence detection of stationary vehicles. Figure 18 shows a typical parking meter arrangement with three possible sensor locations.

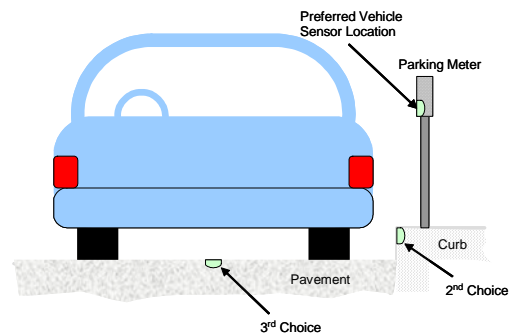

Figure 18 - Parking Meter Sensing

Honeywell provides extensive application engineering support for customers using the HMC family of magnetic sensors. For further questions, please call for applications support at 800-323-8295 (USA toll free) or 763-954-2474 or visit our website at [www.magneticsensors.com](http://www.magneticsensors.com).